

SL3000UL SLIDE GATE OPERATOR

SECTION 32 31 00



KEY FEATURES

REMOTE CONTROL ACCESS	Security+ 2.0® 3-channel receiver will handle up to 50 remote controls (unlimited remotes with 811LMX/813LMX)
INTERNET CONNECTIVITY	myQ® technology monitors and controls the operator through the myQ app
MONITORED SAFETY INPUTS	6 inputs (main and expansion board)
DIAGNOSTIC DISPLAY	LED diagnostic display
WIRELESS DUAL-GATE COMMUNICATION	Eliminates expensive conduit costs and unsightly driveway scars
LIMIT SETTING	Mechanical
PROGRAMMABLE AUXILIARY RELAYS	Easily add additional features, such as warning lights/alarms
UNAUTHORIZED ACCESS PREVENTION	Can be programmed with anti-tailgate or quick close capabilities
HOMELINK® COMPATIBLE	Version 4 and higher

SPECIFICATIONS

OPERATOR SPEED	12 in. per second
POWER	120VAC single phase
ACCESSORY POWER	24VDC, 500mA output
OPERATOR WEIGHT	140 lbs.
WARRANTY	5 years commercial, 7 years residential
TEMPERATURE SPECIFICATIONS	Without heater: -4°F (-20°C) to 140°F (60°C); with optional heater: -40°F (-40°C) to 140°F (60°C)
UL USAGE CLASSIFICATION	UL 325 & UL 991 listed – class I, II, III and IV

CONSTRUCTION

MOTOR	High-temperature (1/2 HP or 1 HP) AC motor with class H insulation for high cycle, high-temperature applications
OPERATOR DUTY RATING	Continuous duty
CHASSIS/FRAME	Constructed with 1/4 in. black powder-coated steel for rust prevention
GEAR REDUCTION	30:1 worm gear reducer in synthetic oil bath
CHAIN	#41 black oxide (50 ft. included)
COVER	High-density UV resistant one piece polyethylene plastic for excellent heat and corrosion resistance
RECOMMENDED CAPACITIES	1/2 HP rated for gates up to 50 ft. in length or weighing up to 1,000 lbs. 1 HP rated for gates up to 50 ft. in length or weighing up to 2,000 lbs.

ACCESSORIES

Important: This operator requires installation of an external monitored entrapment protection device for each entrapment zone. Use only LiftMaster monitored entrapment protection devices itemized on the accessory page of the operators installation manual to meet UL 325 requirements.



DATA SHEET
SLIDE GATE OPERATOR

www.SimpleGateOpeners |
(888) 378-1618 |
Sales@SimpleGateOpeners.com

SL3000UL SLIDE GATE OPERATOR

SECTION 32 31 00

DIMENSIONS

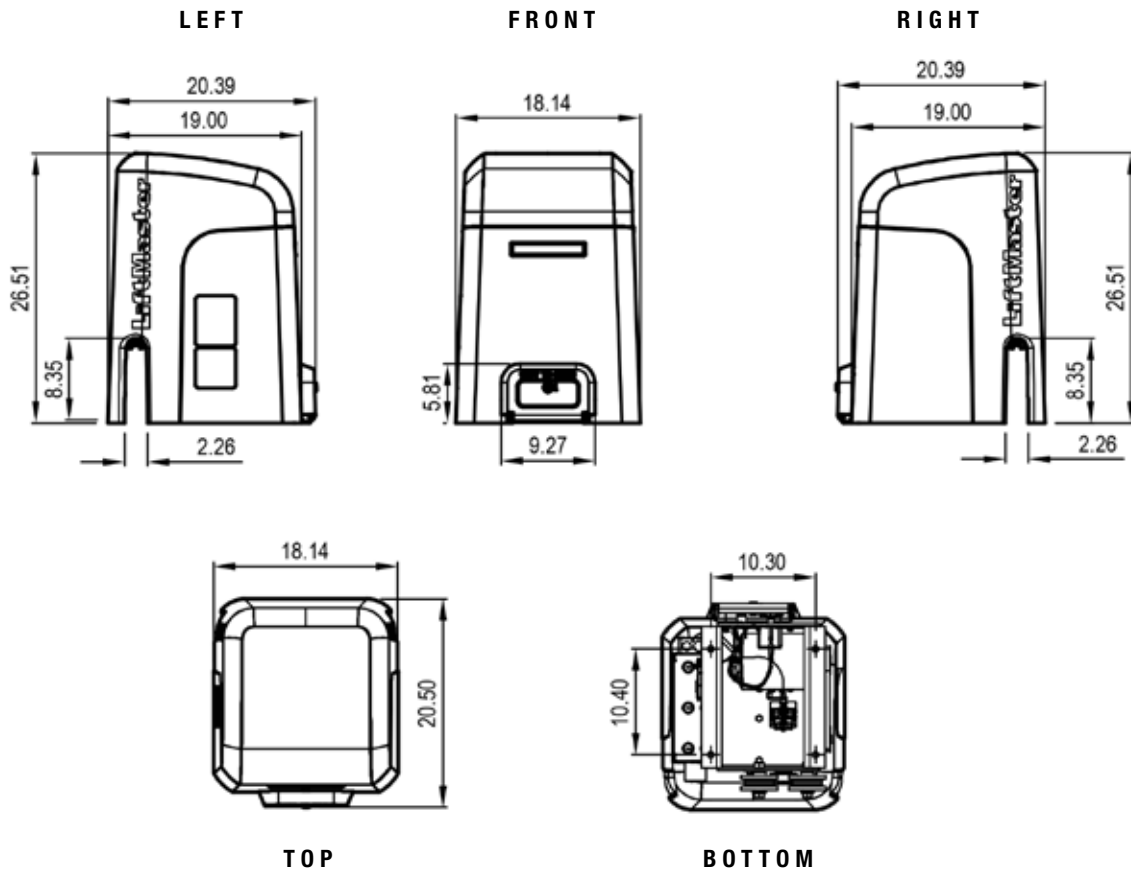

CAPACITY

