

WIRELESS KEYPAD KPW5

SECTION 28 13 00



KEY FEATURES

UNIT INTERFACE CAPABILITIES	PIN
STAND ALONE	Yes
WIRELESS COMMUNICATION	Yes*

SPECIFICATIONS

POWER SUPPLY	9V Lithium Battery (included in carton)
PROGRAMMING (DATABASE MANAGEMENT)	Keypad
LOCAL USER CAPACITY	5
MAX NUMBER OF GATES/DOORS OF CONTROL (EACH)	1
RELAY OUTPUT	1
MOUNTING OPTIONS	Surface/gooseneck
OPERATING TEMPERATURE	-4°F to 140°F (-20°C to 60°C)
CAMERA READY	No
ANTI-TAMPER ALARM	No
WARRANTY	1 year

CONSTRUCTION

ENCLOSURE MATERIAL	Polycarbonate
---------------------------	---------------

*When used with LiftMaster® operators with Security+ 2.0® Radio

DATA SHEET
WIRELESS KEYPAD



LiftMaster®

www.SimpleGateOpeners.com | (888) 378-1618 | Sales@SimpleGateOpeners.com

WIRELESS KEYPAD KPW5

SECTION 28 13 00

DIMENSIONS

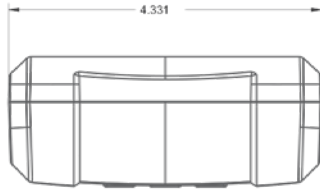

TOP

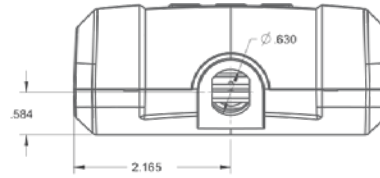

BOTTOM



LEFT

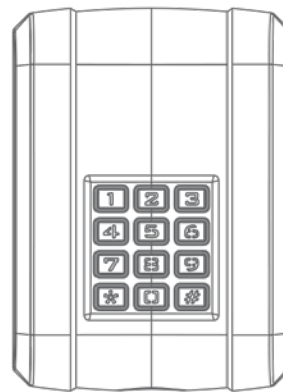

FRONT

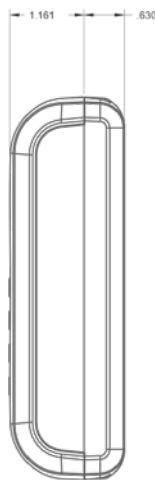

RIGHT

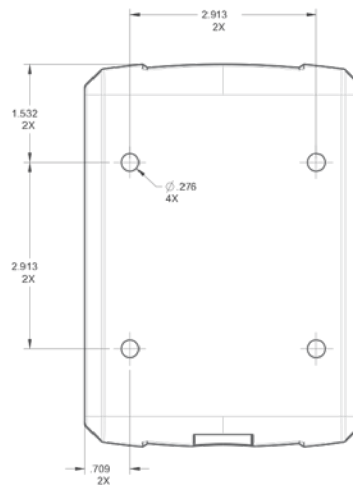

REAR