

# K72-12532

## Output Shaft Assembly Service Kit for J-Line Operators

### APPLICATION REQUIREMENTS:

Replacement of Output Shaft and/or its components for a Model J Operator.

### PACKING LIST:

ITEM	PART NUMBER	DESCRIPTION	QUANTITY
1	11-10879	Output Shaft	1
2	12-10891	1" I.D. Ball Bearing	2
3	15-10885	48B32/48B14 Idler Sprocket Assembly	1
4	15-48B32LXX	48B32 Sprocket	1
5	15-48B18LGE	Sprocket, 48B18 LGE	1
6	15-50B12LGF	Sprocket, 50B12 LGF	1
7	19-48047M	#48 Chain 47P W/ML	2
8	80-206-10	Spacer 1-1/32 x 1-1/2 x 1/64	2
9	80-206-11	Spacer 1-1/16 x 1-1/2 x 1/16	5
10	80-207-19	Key 1/4 x 1/4 x 1-1/2	2
11	87-E-100	E Ring, 1" Plated	3
12	13-18691	Shaft Collar	2

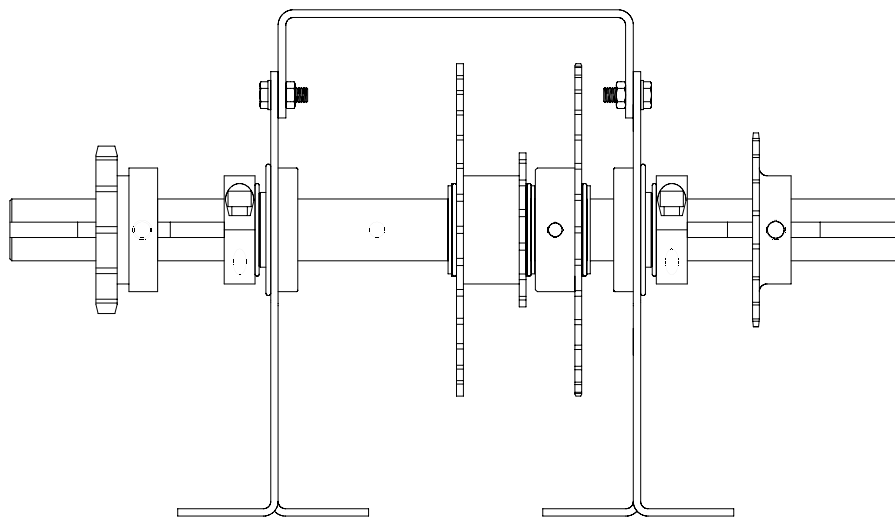
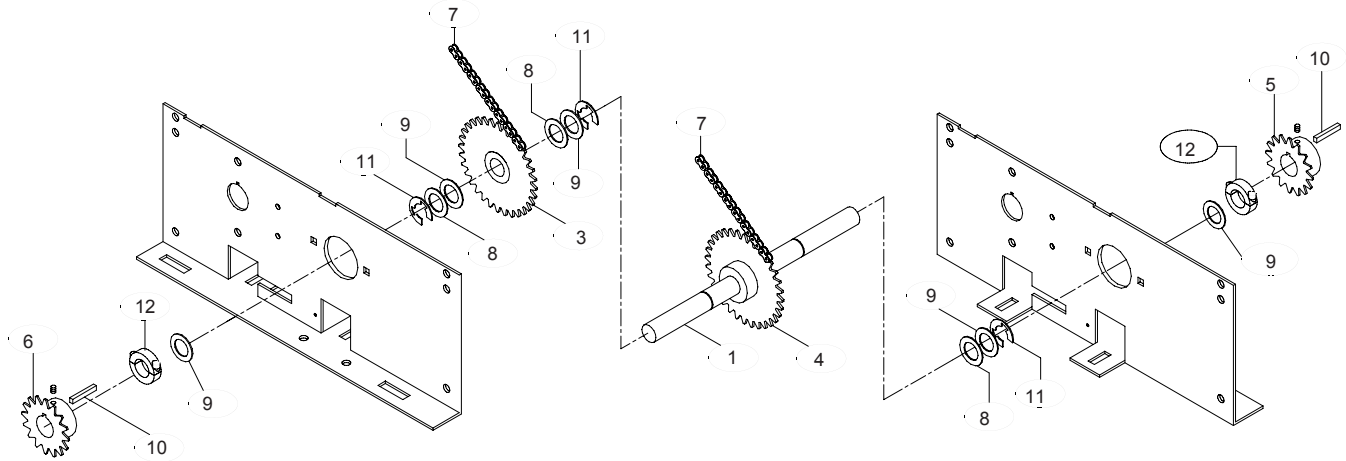

**END VIEW**

# INSTALLATION INSTRUCTIONS



## WARNING

**DISCONNECT POWER AT THE FUSE BOX BEFORE PROCEEDING. IF NECESSARY REMOVE THE OPERATOR FROM ITS MOUNTED POSITION.**

**NOTE:** Refer to the Owner's Manual supplied with the operator for all mounting and wiring instructions.

### **REMOVE EXISTING SHAFT:**

Remove the master links from the limit and output chains. Remove the chains and set them aside. Remove the drive belt from the clutch and set it aside. Remove the four screws connecting the Motor Plate to the Motor Frame. Lift off the Motor Plate and set it aside.

Disconnect and remove the three interior chains connecting the clutch and output shafts. Remove all push on fasteners from the output shaft. Remove the output shaft limit sprocket by first loosening the set screw and then sliding it off the shaft along with its key. Loosen the set screw of the 48B32 sprocket.

Slide the output shaft out of the Motor Frame from the output sprocket side. The interior sprockets and shim washers will slide off the shaft as it is removed. Remove the two ball bearings from the Motor Frame.

### **INSTALLING NEW OUTPUT SHAFT:**

Press the new ball bearings into the Motor Frame. Referring to the illustration above, attach new output sprocket to the new output shaft along with a key using the set screw. Do not fully tighten the set screw at this time. Refer to the illustration and the Owner's Manual as necessary for the remainder of the installation. Add the necessary shim washers. Slide the new output shaft into the Motor Frame, picking up the appropriate washers and sprockets in the reverse order from how they were removed before. Align the two interior sprockets by re-attaching the three lengths of chain connecting the clutch and output shafts. Tighten the 48B32 sprocket with its set screw and secure the combination sprocket with push on fasteners. Secure the new output shaft in the Motor Frame with the shaft collars and washers supplied and re-attach the Motor Plate.

Replace the limit chain and the drive belt. Restoring power completes the installation.